

Operating Instructions

Drill rig

DRU160★ ★ ★

Index 001

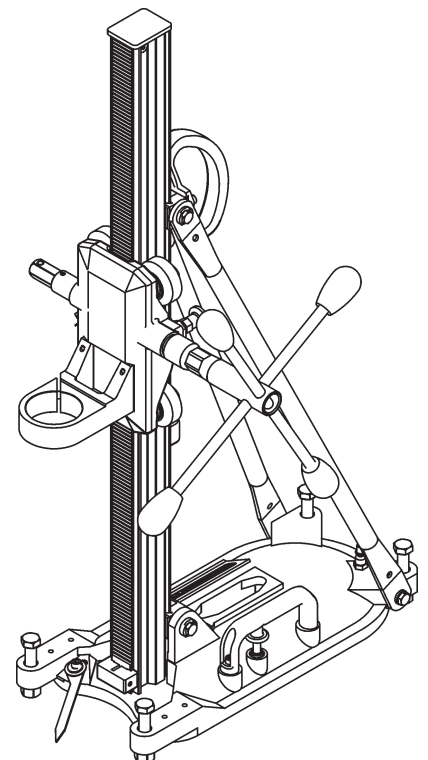

Congratulations!

With a Hydrostress unit from TYROLIT you have chosen a tried and tested piece of equipment designed and built to the highest technical standards. Only genuine TYROLIT Hydrostress replacement parts can guarantee quality and interchangeability. If maintenance work is neglected or carried out inexpertly we will be unable to honour our warranty obligations. Any repair work must be carried out by trained personnel only.

Our after-sales service is available to help ensure that your TYROLIT Hydrostress units remain in perfect working order.

We hope that working with your TYROLIT unit will be a satisfying and fault-free experience.

TYROLIT Hydrostress

Copyright © TYROLIT Hydrostress

TYROLIT Hydrostress AG
Witzbergstrasse 18
CH-8330 Pfäffikon
Switzerland
Tel. 0041 (1) 952 18 18
Fax 0041 (1) 952 18 00

1 Safety



These instructions are just one part of the documentation which is supplied together with the drill rig. These instructions go together with the "Core Drills Safety Manual / System Description" to form a complete set of documentation.



DANGER

Failure to comply with the safety instructions in the "Core Drills Safety Manual / System Description" may result in serious injury or even death.

- ▶ Please ensure that the "Core Drills Safety Manual / System Description" has been read and understood.



DANGER

Death or serious injury can be caused by a sudden start-up of the machine.

- ▶ Before switching on the system, ensure that no other person is present in the danger areas.
- ▶ Switch the system off before connecting or disconnecting cables.
- ▶ Switch the system off when you leave and secure it so that it cannot be switched back on again.

Death or serious injury as a result of the drill bit continuing to run after an accident.

- ▶ Ensure that the EMERGENCY STOP button can be reached quickly.

Electric shock from live cables and connectors.

- ▶ Switch the drill motor off before connecting or disconnecting cables.

Risk of fire due to incorrect mains voltage.

- ▶ Make sure that the mains voltage and mains frequency match the mains settings of the drill motor.

2 Description

2.1 Core drilling system

The DRU160*** drill rig is part of core drill systems comprising the appropriate TYROLIT Hydrostress components.

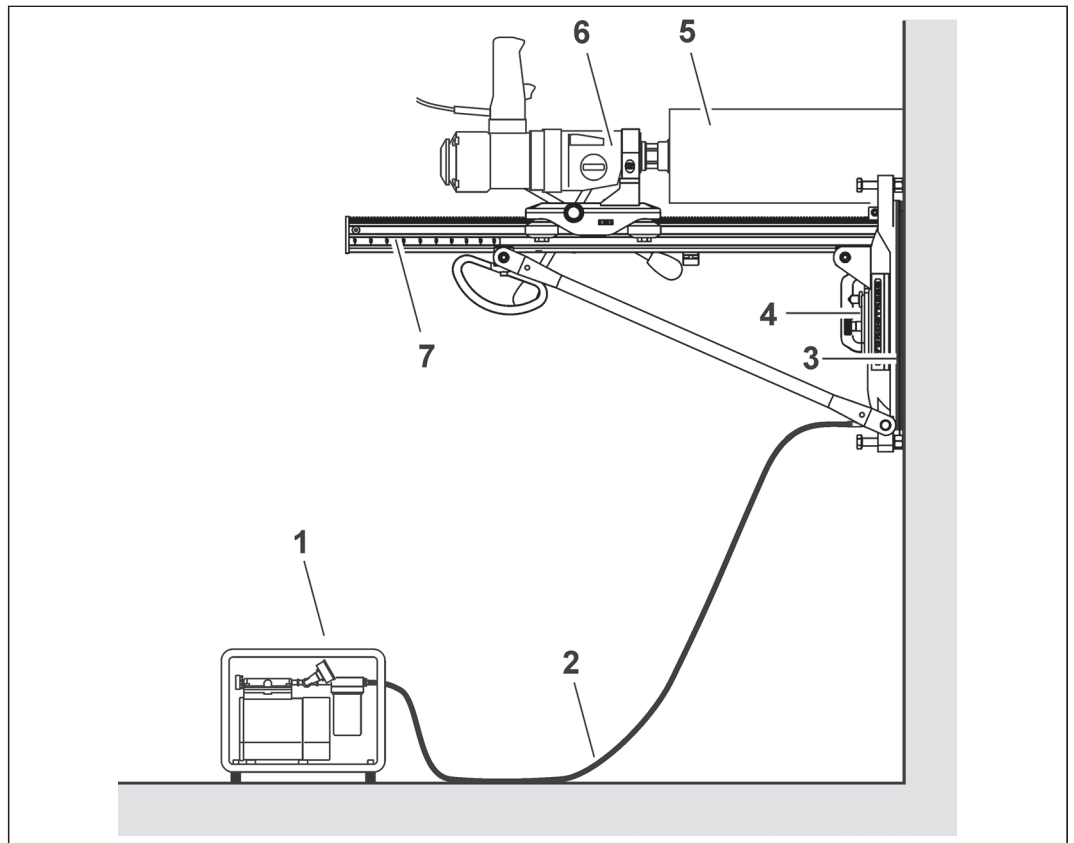

Core drilling system

- | | |
|---------------|---------------|
| 1 Vacuum pump | 5 Drill bit |
| 2 Vacuum hose | 6 Drill motor |
| 3 Vacuum seal | 7 Drill rig |
| 4 Vacuum cap | |

2.2 Main components of the DRU160★★★

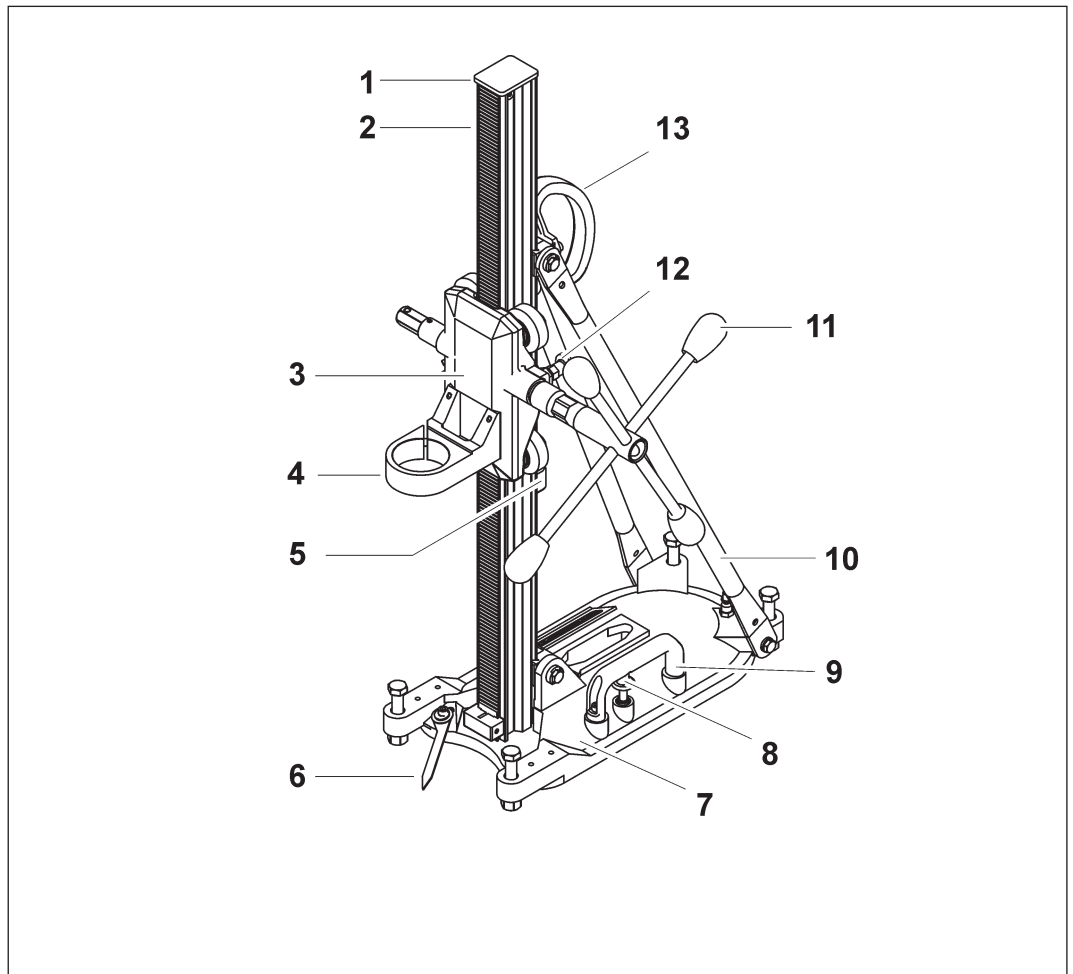

Main components of the DRU160★★★

- | | |
|--------------------|-----------------------|
| 1 Cap | 8 Vacuum valve |
| 2 Column | 9 Handle |
| 3 Support | 10 Support rod |
| 4 Clamping collar | 11 Hand crank |
| 5 Level | 12 Locking hand crank |
| 6 Centre indicator | 13 Grip |
| 7 Vacuum foot | |

3 Assembly

3.1 Locking the support

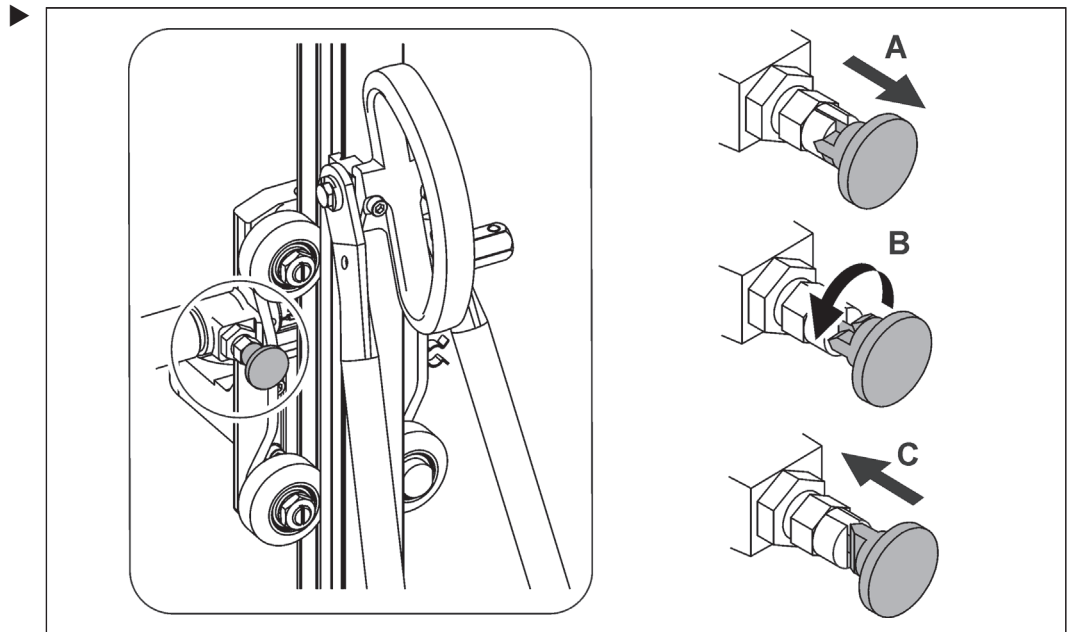

3.2 Drill motor interface

- ✓ Lock the support before securing the drill motor.
(see 3.1 Locking the support)

3.2.1 Mounting the drill motor

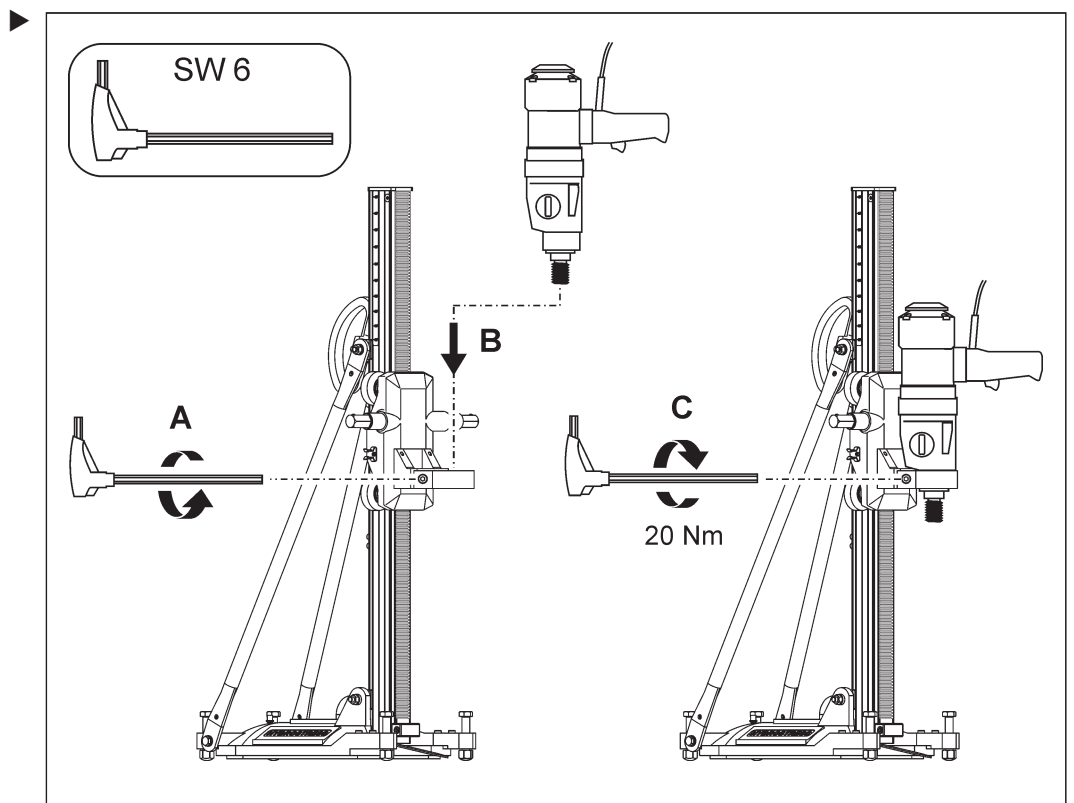

3.3 Surface interface

3.3.1 Dowel anchoring

The DRU160*** drill rig can be securely attached to the surface with dowel anchoring. Information on safe dowel anchoring can be found in the "Core Drills Safety Manual / System Description".

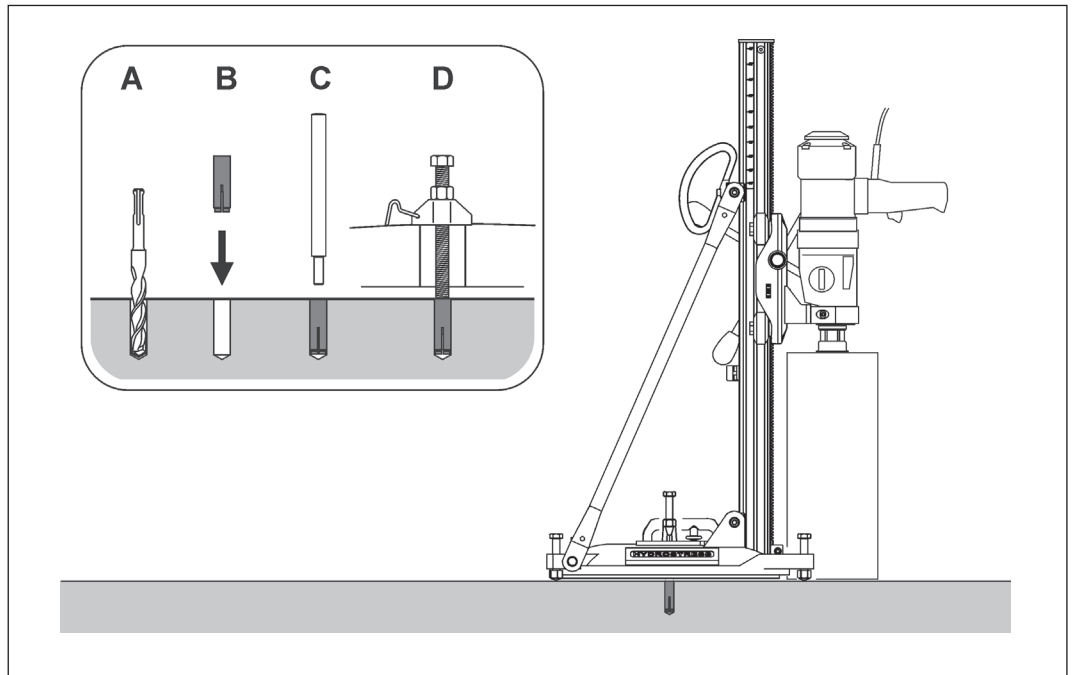

3.3.2 Vacuum fixing

The DRU160*** drill rig can be securely attached to the surface with the appropriate TYROLIT Hydrostress components. Information on safe vacuum anchoring can be found in the "Core Drills Safety Manual / System Description".

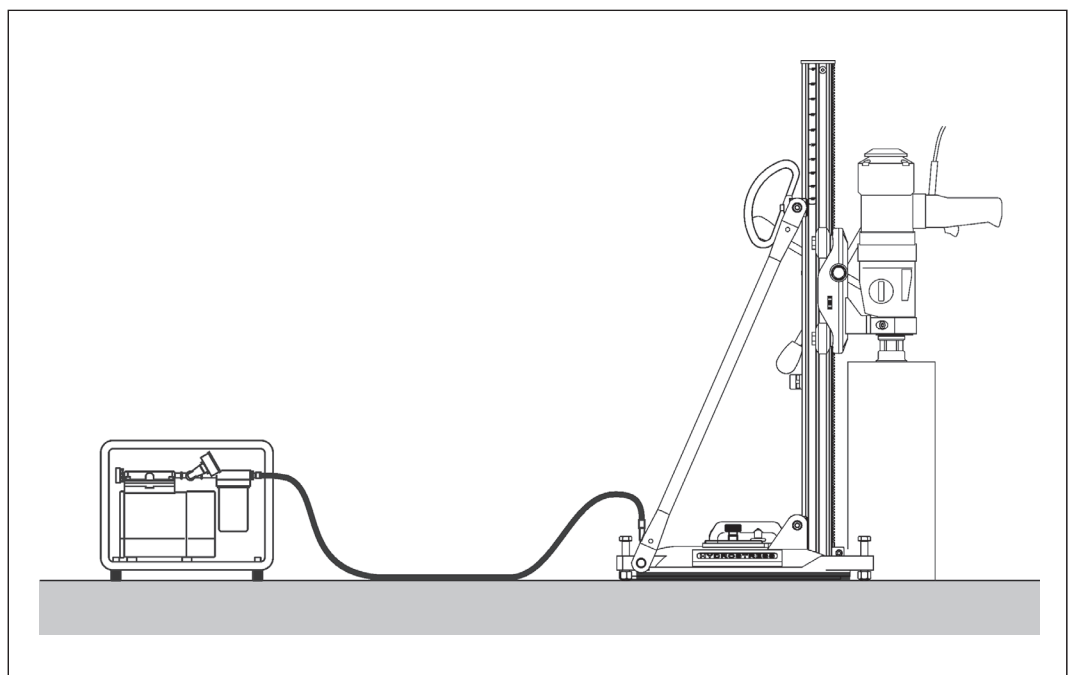

4 Settings

4.1 Angled position

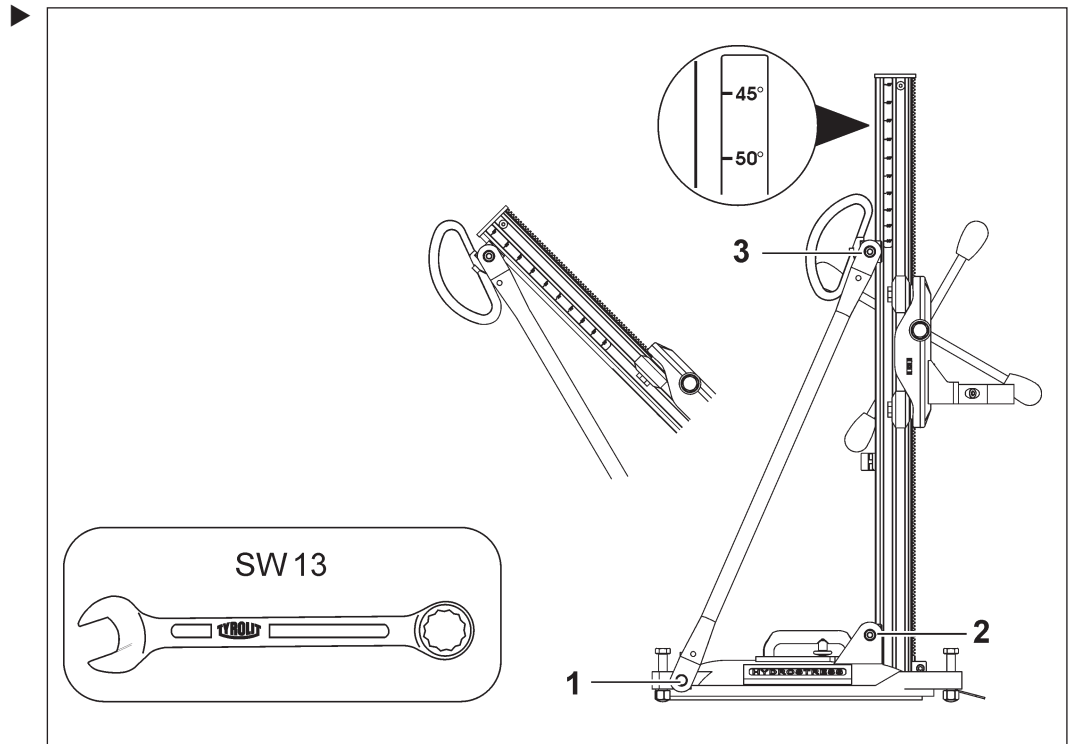

4.2 Brake

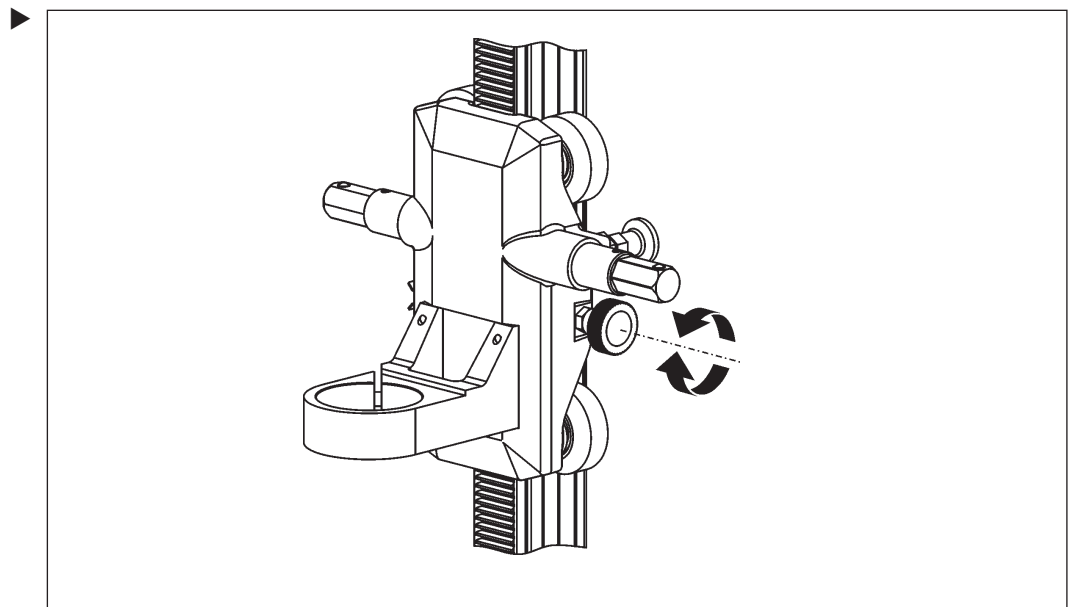

4.3 Adjusting the rollers

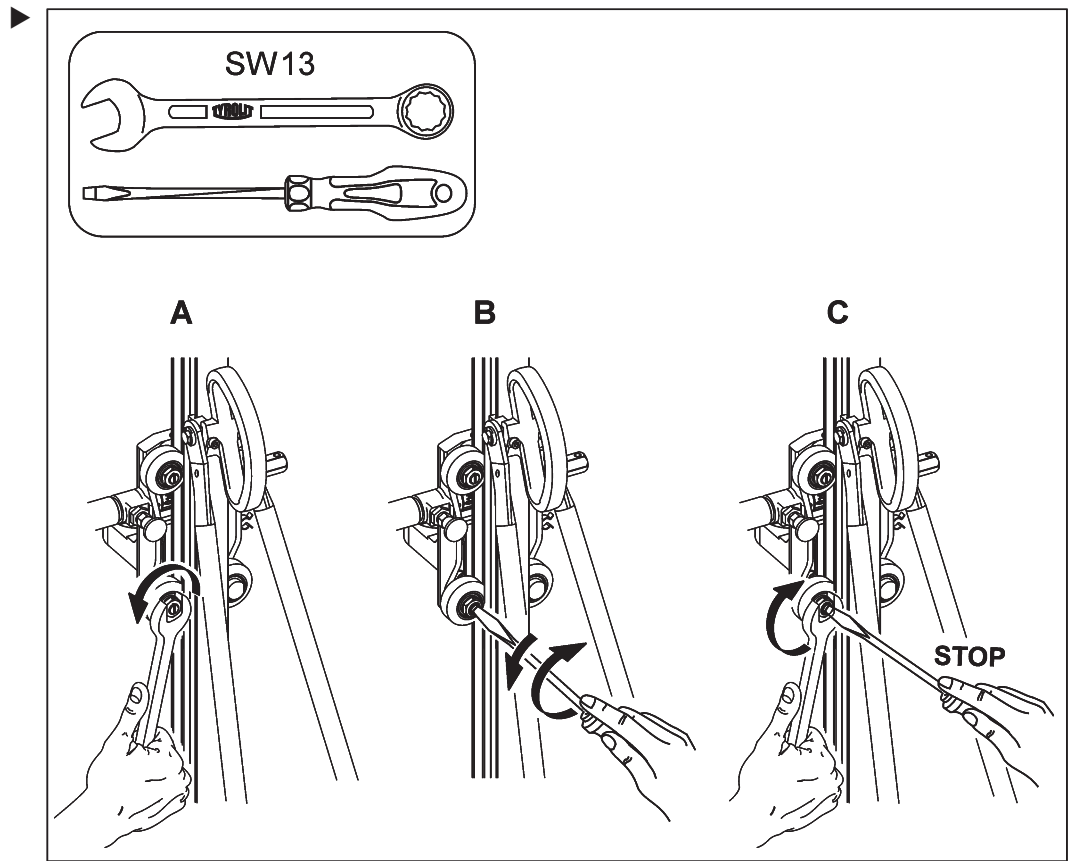

5 Servicing and maintenance

Maintenance and servicing table								
		Before starting up (every time)	At end of work	Weekly	Yearly	After faults	After damage	
Drill rig	▶ Wash down with water		X			X	X	
	▶ Lubricate threads of adjustable feet			X		X	X	
	▶ Tighten loose screws and nuts	X						
	▶ Clean teeth of guide column		X			X		
Support	▶ Tighten loose screws and nuts	X				X	X	
	▶ Check roller guide and adjust if necessary (see roller adjustment 4.2)	X				X		
	▶ Replace roller guide						X	
Service	▶ To be performed by TYROLIT Hydrostress AG or an authorised workshop.	First service after 100 operating hours Further services after every further 200 operating hours						

6 Faults

Malfunctions		
Malfunction	Possible cause	Solution
Diamond drill bit jams	Diamond drill bit off centre due to inadequate anchoring of guide rail or drill rig foot	▶ Loosen and extract diamond drill bit. Break up drilling core and correct drill rig anchoring.
	Diamond drill bit drifts due to excessive play in the roller guides	▶ Loosen drill rig and readjust roller guides
	Drill segments are worn (No free cutting)	▶ Replace drill bit
Major wear on the drill bit tube	Diamond drill bit poorly guided in the drill hole	▶ Adjust roller guides
	Defective drill motor bearings	▶ Replace drill motor ▶ Contact TYROLIT Hydrostress AG aftersales.
Feed jams along the whole length of the guide rail	Locking device on the roller guides is too tight.	▶ Adjust roller guide clamping
Feed jams at one point on the guide rail	Guide rail is distorted or damaged	▶ Contact TYROLIT Hydrostress AG aftersales
Difficulty in centring drill bit	Diamond drill bit off centre due to poor anchoring of the drill rig	▶ Correct drill rig anchoring
	Diamond drill bit drifts due to excessive play in the roller guides	▶ Adjust roller guides
	Poor concentricity of drill bit	▶ Replace drill bit ▶ Use TYROLIT diamond tool
Difficult or impossible to twist the foot adjustment screw	Thread not lubricated	▶ Lubricate thread
	Feet distorted	▶ Contact TYROLIT Hydrostress AG aftersales
Difficult or impossible to incline the drill rig	Guide rail distorted or damaged	▶ Contact TYROLIT Hydrostress AG aftersales.
Vacuum cannot be generated	Defective vacuum seal on vacuum foot	▶ Replace vacuum seal
	Defective vacuum valve on vacuum foot	▶ Replace vacuum valve
	Defective vacuum pump or hose	▶ Replace vacuum pump or hose
	Surface not suitable for vacuum anchoring	▶ Choose another type of anchoring

7 Technical data

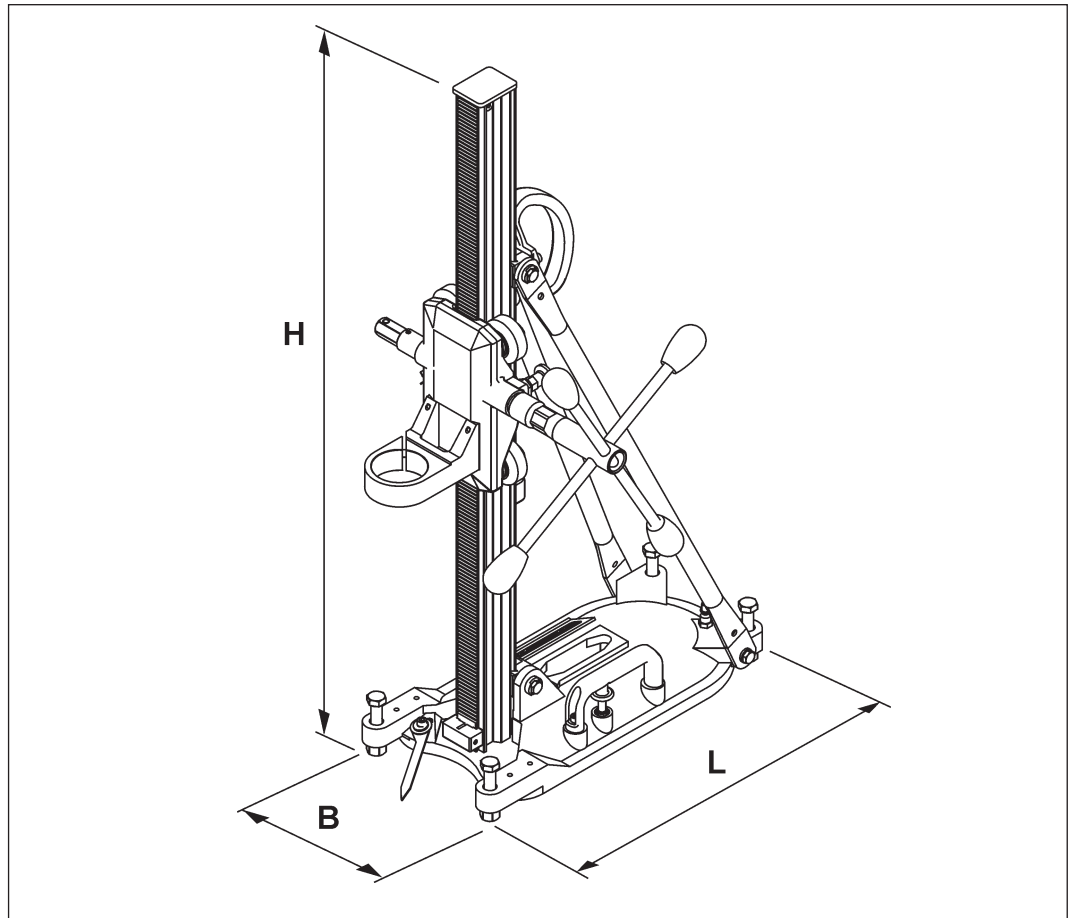

Dimensions

Dimensions	
DRU160 ★★★	
Length L	400 mm
Width B	200 mm
Height H	866 mm

Weights	
DRU160 ★★★	
Weight (without hand crank)	9 kg

Drill bits	
DRU160 ★★★	
Drill diameter range with dowel anchoring	up to Ø 160 mm
Drill diameter range with vacuum anchoring	up to Ø 160 mm
Max. drill diameter with water collection ring	Ø 130 mm
Max. drill bit length	560 mm

Design	
DRU160 ★★★	
Foot	Aluminium dowel vacuum foot
Feed	by hand crank
Angular adjustment	90°-45° with angle display
Centre indicator	Indicator retractable
Adjustable feet	M12 bolt
Drill motor mount	Clamping collar
Support guide	Adjustable interchangeable roller guide

8 EC Declaration of Conformity

Description	Drill rig
Type designation	DRU160★ ★ ★

We declare under our sole responsibility that this product complies with the following directives and standards:

Directive applied

2006/42/EC

Applied standards

EN 12100 : 2010

EN 12348 : 2000 + A1 : 2009

Pfäffikon, 12.05.2017



Pascal Schmid
Head of Development

