

# ***Safety Manual*** ***System Description***

---

## ***Floor saws***

*Issue: 2.12.08*

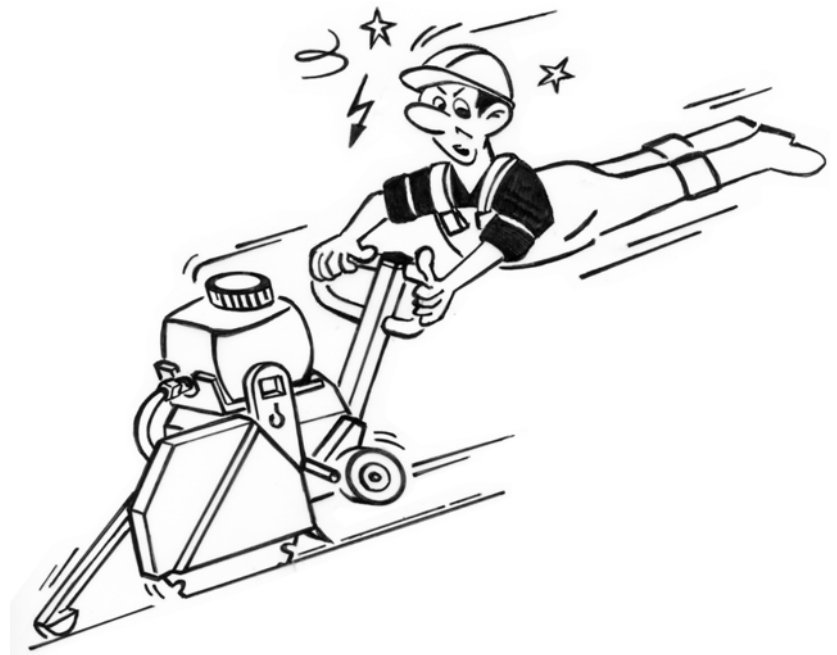

**Manufacturer's address**

**TYROLIT Hydrostress AG  
Witzbergstrasse 18  
CH-8330 Pfäffikon  
Switzerland  
Phone +41 (0) 44 / 952 18 18  
Fax +41 (0) 44 / 952 18 00**

TYROLIT Hydrostress AG reserves the right to make technical changes without prior notice.

Copyright © 2008 TYROLIT Hydrostress AG, CH-8330 Pfäffikon ZH

All rights reserved, in particular copying and translation rights.

Reprinting of extracts from this safety manual is prohibited. No part of these Operating Instructions may be reproduced in any form whatsoever or be processed, copied or distributed using electronic systems without the written permission of TYROLIT Hydrostress AG.

# Overview

	Page
<b>0</b>	<b>Introduction</b> <span style="float: right;"><b>1</b></span>
0.1	Document structure ----- 1
0.2	Terms ----- 1
0.3	Pictograms ----- 2
<b>1</b>	<b>Technical data</b> <span style="float: right;"><b>1</b></span>
1.1	Recommended ambient temperature ----- 1
1.2	Water connection ----- 1
1.3	Cutting speed ----- 1
1.4	Specification for oils and grease ----- 1
1.5	Weights ----- 2
1.6	Name plates ----- 2
<b>2</b>	<b>Safety instructions</b> <span style="float: right;"><b>1</b></span>
2.1	General ----- 1
2.2	Information and symbols ----- 2
2.3	Safety principles ----- 6
2.4	General safety rules ----- 8
2.5	Responsibility ----- 11
<b>3</b>	<b>Design and function</b> <span style="float: right;"><b>1</b></span>
3.1	Functional description ----- 1
<b>4</b>	<b>Assembly , disassembly</b> <span style="float: right;"><b>1</b></span>
4.1	General ----- 1
4.2	Saw blade assembly ----- 1
<b>5</b>	<b>Putting into service / Operation</b> <span style="float: right;"><b>1</b></span>
5.1	Putting into operation ----- 1
5.2	General ----- 1
5.3	Safety-related operator's controls ----- 5
5.4	Operation ----- 7
5.5	Removal of the structural blocks ----- 16
5.6	Securing of floor or ceiling cutouts ----- 17
5.7	Troubleshooting ----- 18
<b>6</b>	<b>Maintenance</b> <span style="float: right;"><b>1</b></span>
6.1	General ----- 1
6.2	Maintenance interval table ----- 2
6.3	Inspection ----- 3
6.4	Maintenance ----- 3
6.5	Corrective maintenance ----- 3
<b>7</b>	<b>Disposal</b> <span style="float: right;"><b>1</b></span>
7.1	General ----- 1
7.2	Safety instructions ----- 1
7.3	Personnel qualifications ----- 1
7.4	Disposal regulations ----- 1
7.5	Disposal of installation components ----- 2
7.6	Obligation of notification ----- 2



## 0 Introduction

### 0.1 Document structure

The Safety Manual contains a description on how to safely operate Floor saws. Safety instructions specific to each machine will be found in the corresponding Operating Instructions and must likewise be strictly adhered to.





### 0.2 Terms





#### 0.2.1 Terms related to Floor saws



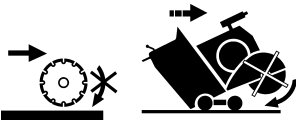
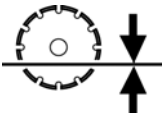
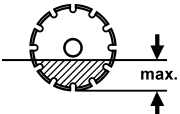
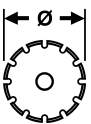
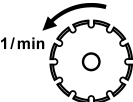



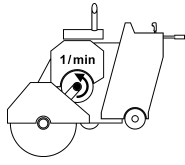
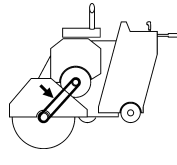
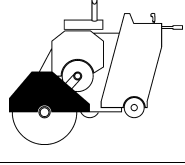
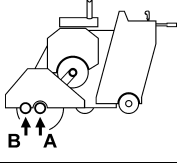





Term	Definition
Motors	A distinction is made between a drive motor (tool) and a feed motor (travelling motion). Electric motors, hydrostatic, diesel or petrol motors are used.
Cutting tool	The diamond saw blade is referred to as a cutting tool.
Blade guard	The blade guard is a safety device that prevents accidental contact with the tool, intercepts flying parts and at the same time acts as a spray guard.
Guide cut	Guide cuts serve to guide the diamond saw blade and should be followed for safety reasons.
Precut	Large depths cannot be cut in a single pass. Therefore, for blade diameters of Ø700 mm and above precuts must be made. The precuts must be performed with a diamond saw blade of small diameter and with wide segments.

### 0.3 Pictograms

#### 0.3.1 Pictograms related to Floor saws

Pictogram	Definition
	Diamond saw blade On / Off
	Lower diamond saw blade
	Raise diamond saw blade
	Travelling motion Floor saws (feed motion)
	Important: When sliding the Floor saws when it is not cutting the diamond saw blade should not rotate.
	Cutting depths locking
	Maximum cutting depth
	Saw blade diameter
	Saw blade speed

Pictogram	Definition
	<p>Apply brake</p>
	<p>Release brake</p>
	<p>Motor speed</p>
	<p>Drive belt specification</p>
	<p>Blade guard size</p>
	<p>Drive shaft selection</p>
	<p>Blade holder flange diameter</p>
	<p>Drive wheel diameter Saw blade belt wheel / Motor belt wheel</p>

Pictogram	Definition
	Water supply
	Water pump
	Light
	Battery
	Fuel Petrol / Diesel
	Display: oil temperature
	Display: oil
	Feed gears On
	Feed gears Off
	Preheat motor
	Fast
	Slow



# 1 Technical data

## 1.1 Recommended ambient temperature

Storage: between -15 °C and 50 °C

Usage: from -15 °C to 45 °C

**Warning:** At sub-zero temperatures to as low as -15°C antifreeze can be used. If the system is shut down or at a standstill for long periods, the cooling water must be blown out of the system.

## 1.2 Water connection

Pressure: min. 1 bar to max. 6 bar at 25 °C

Quantity: min. 6 l/min.

## 1.3 Cutting speed

This must be selected according to the nature of the material.

The recommended values in m/sec. are:

Old concrete with hard aggregate materials, high reinforcement	35 - 45 m/s
---	-------------

Old concrete with soft aggregate materials; low reinforcement	45 - 50 m/s
--	-------------

New concrete, asphalt, etc.	50 - 63 m/s
-----------------------------	-------------

Maximum permitted cutting speed for TYROLIT tool	63 m/s
---	--------

## 1.4 Specification for oils and grease

### 1.4.1 Hydraulic oil

Dexron ATF II D

### 1.4.2 Lubricating grease

Polyrex EM (K2P - 20 DIN 51825)



### Information

For oils and greases for drive motors see operating instructions from the respective manufacturers.

## 1.5 Weights

- Relative densities:
  - Asphalt:  $1.5 \text{ t/m}^3 = 1500 \text{ kg/m}^3$
  - Reinforced concrete:  $2.7 \text{ t/m}^3 = 2700 \text{ kg/m}^3$

### 1.5.1 Weight calculation (example):

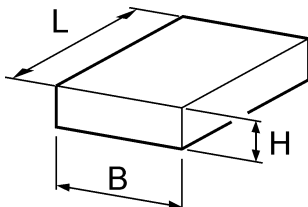

Fig. 1-1 Weight calculation for building structures

- Calculation formula:  $L \times B \times H \times \text{material} = \text{Weight}$
- Example (reinforced concrete):  $1 \times 0.5 \times 0.3 \times 2,700 = 405 \text{ kg}$
- Material in  $\text{kg/m}^3$
- Weight in kg

## 1.6 Name plates

All data specific to the type of machine and components can be found on the name plates fitted.

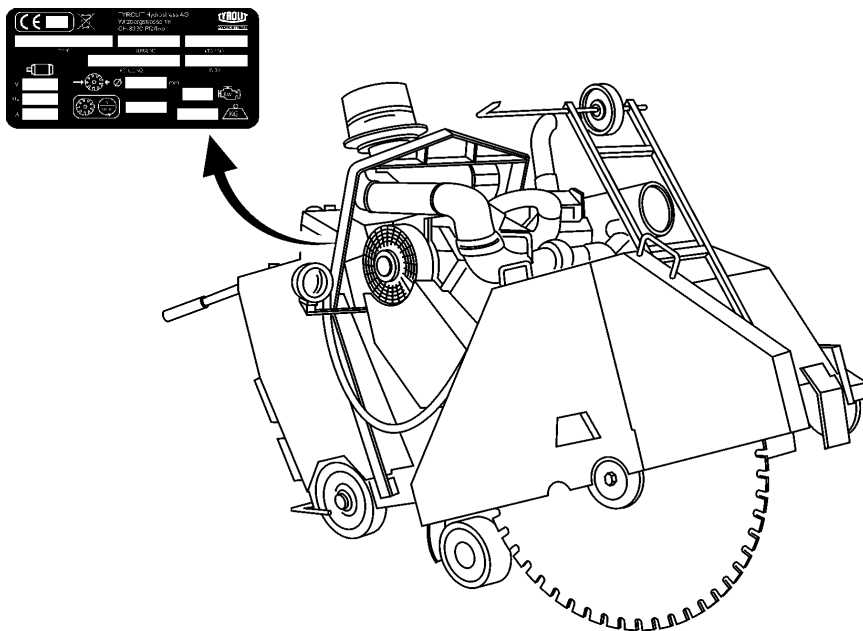

Fig. 1-2 Name plates

## **2 Safety instructions**

### **2.1 General**

#### **2.1.1 Target audience**

This chapter describes the safety instructions that it is essential to follow when using Floor saws.

No work must be performed on or with Floor saws before the safety instructions contained in the Safety Manual and in the Operating Instructions have been read and understood.

#### **2.1.2 Observance of the safety instructions**

Floor saws are inspected before being shipped and are delivered in perfect condition. TYROLIT Hydrostress AG does not accept any liability for damage caused by the failure to observe the instructions and information provided in the Safety Manual and in the Operating Instructions. This applies in particular to:

- Damage caused by improper use and operator error.
- Damage caused by improperly installed third-party components.
- Damage caused by failure to observe safety-related information in the Safety Manual or shown on the warning signs fitted to the machine.
- Damage caused by defective or neglected maintenance work.
- Damage caused by cutting unauthorised material.

Independently performed conversions and alterations may affect safety and are not permitted.

## 2.2 Information and symbols

### 2.2.1 Hazard symbols

In this Safety Manual and in the Operating Instructions information panels are used to draw attention to residual dangers and to point out important technical requirements.

#### Hazard symbols

#### 2.2.1.1 Hazard symbols in the Safety Manual



<b>Danger</b>
<b>Warning of danger, where failure to comply could lead to death or serious injury.</b>



<b>Warning</b>
<b>Warning of danger, where failure to comply could lead to injury and/or damage to property.</b>

#### Information symbols

#### 2.2.1.2 Information symbols in the Safety Manual



<b>Information</b>
Text displayed in this way is practical information and is aimed at achieving optimum use of the installation or apparatus. Failure to take note of this information may mean that the performances shown in the technical data can no longer be guaranteed.

### 2.2.2 Instructions on the product



<b>Danger</b>
<b>Voltage warning</b>
<b>Before working in an area identified in this way, the installation or device must be fully disconnected from the power (voltage) and secured against being accidentally powered up again.</b>
<b>Failure to heed this warning may lead to death or serious injury.</b>

### 2.2.3 Generally applicable warnings of residual dangers

The following contains warning and danger information that is generally applicable to all work with and on Floor saws.

Generally applicable danger information:



<b>Danger</b>	
	<p><b>Danger from incorrect handling of Floor saws.</b></p> <ul style="list-style-type: none"> <li>- In the event of a malfunction, immediately shut down and secure the machine. Clear malfunctions immediately.</li> <li>- Use only TYROLIT saw blades and saw blades that are suitable for Floor saws. Observe the permitted speed and direction of rotation of the saw blade. Never work with damaged saw blades.</li> <li>- Manoeuvres must only be performed with the blade drive motor at a standstill.</li> <li>- In the event of transport by crane, ensure that no-one is standing below the suspended load. Always have the Floor saws in your line of vision.</li> <li>- During loading operations use only lifting tools and load suspension devices with sufficient load-bearing capacity.</li> <li>- Appoint an expert marshaller for the lifting procedure.</li> <li>- Machines must always be lifted correctly in accordance with the operating instructions (anchorage points for load suspension devices, etc.).</li> <li>- Always use appropriate transport means with sufficient load-bearing capacity.</li> </ul> <p>Failure to comply with this regulation may lead to serious physical injury or death. Secondary damage such as fires may also occur.</p>



<b>Danger</b>	
	<p><b>Explosion hazard</b></p> <p>Starting of fires and smoking in the immediate vicinity of Floor saws is strictly prohibited.</p> <p>Failure to comply with this regulation may lead to serious physical injury or death. Secondary damage such as fires may also occur.</p>





## Danger

**Danger of electric shock from electrotechnical equipment.**

- The electrotechnical equipment must be checked prior to each use and from time to time during prolonged use. Defective parts, such as e.g. cables and plugs, must be replaced immediately in the de-energized state by electrotechnically trained personnel.
- Use only original fuses with the specified current rating. In the event of a malfunction of the energy supply, shut down the machine immediately.
- Work on electrical equipment should only be performed by qualified electrical staff or by trained personnel under the direction and supervision of a qualified electrical staff member in accordance with the electrotechnical regulations.
- The electrical equipment of a machine must be regularly inspected/checked. Defects, such as loose connections or damaged cables must be cleared immediately.
- During wet cutting, ensure that the flushing water does not come into contact with electrical lines.

**Failure to comply with this regulation may lead to serious physical injury or death. Secondary damage such as fires may also occur.**

Generally applicable warning notices:

<b>Warning</b>	
  	<p><b>Danger from incorrect handling of Floor saws.</b></p> <ul style="list-style-type: none"> <li>- Touching a cutting tool whilst it is still in motion is prohibited.</li> <li>- When touching cutting tools it is recommended that protective gloves are worn.</li> <li>- Persons who have an allergic reaction to hydraulic oil must wear protective gloves and goggles when carrying out work where they come into contact with hydraulic oil. Any areas of the skin affected must be rinsed immediately with copious amounts of water.</li> <li>- When dry cutting, ensure that there are no combustible materials in the working area.</li> </ul> <p><b>Failure to observe this regulation may result in physical injury.</b></p>

Generally valid information

<b>Information</b>	
	<p>Floor saws are described without combustion engines or electric motors. It is essential to observe the operating instructions of the motor manufacturer.</p>

## **2.3 Safety principles**

### **2.3.1 Delimitation of the safety concept**

The Floor saws have no effect on the safety concept of other systems, apparatus and installations.

### **2.3.2 Safety elements**

Protection of users is based primarily on a safety concept and design safety.

#### **2.3.2.1 Passive safety elements**

##### **Protection from live electrical parts**

All functional units containing parts which carry hazardous voltages are shock-protected by suitable covers.

### **2.3.3 Removal of protective devices**

Protective devices may only be removed if the unit has been switched off, disconnected from the mains and is at standstill. Covers in particular should only be removed and refitted by authorised personnel (see Chapter 2.5.1 "Authorised personnel", 2-11).

The only exception should be the changing of tools, including blade guard and saw head, but then only when the Emergency Stop button has been pressed.

Before using the Floor saws again, the safety elements must be checked for correct operation.

### **2.3.4 Safety measures (organisational)**

#### **2.3.4.1 Product monitoring obligation**

Operating personnel must notify changes in operational behaviour or of safety-related parts to a responsible person or the manufacturer immediately.

#### **2.3.4.2 Location of the Safety Manual**

A copy of the Safety Manual must be available at all times to staff at the place of use of the apparatus.



### 2.3.5 Safety measures (personnel)

#### 2.3.5.1 Individual protective equipment

Anyone working with and on Floor saws is required to wear individual protective equipment.

The individual protective equipment comprises the following:

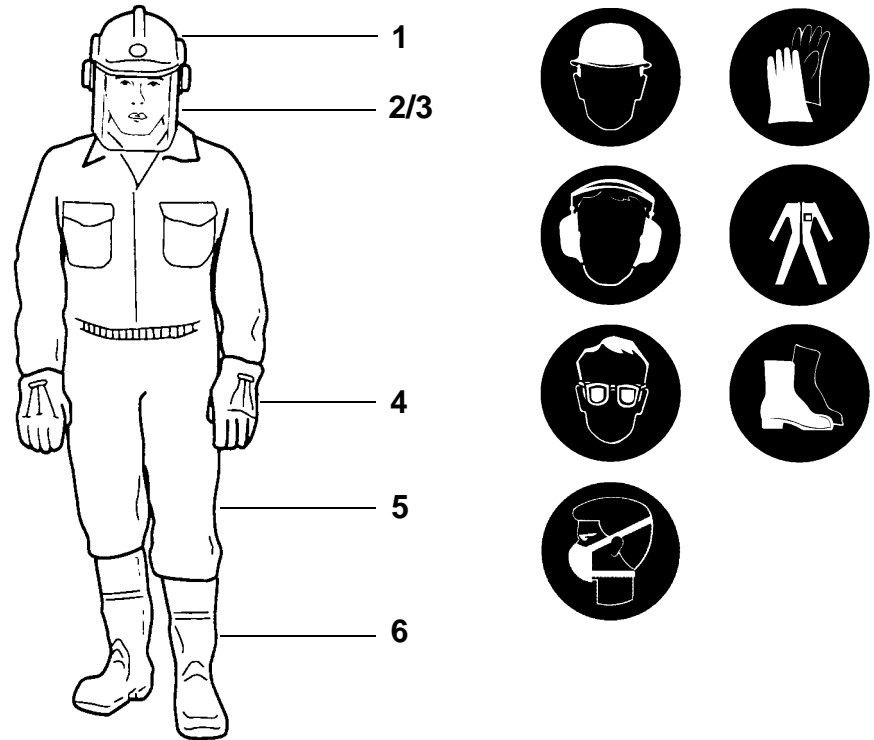

Fig. 2-1 Individual protective equipment

- |                               |  |
|-------------------------------|--|
| 1. Helmet with ear protectors | 5. Close-fitting, sturdy, comfortable clothing       |
| 2. Visor or goggles           | 6. Work boots with steel toecaps and anti-slip soles |
| 3. Respiratory mask           |  |
| 4. Safety gloves              |  |

The specific safety instructions given in the individual chapters may sometimes contain only some of the pictograms shown above. These relate to safety measures to be taken solely in relation to the associated specific hazard and therefore do not excuse the operator from heeding this instruction to wear all the items of individual protective equipment listed above.

## **2.4 General safety rules**

### **2.4.1 Statutory provisions**

The generally applicable national and local safety and accident prevention provisions and the supplementary operator regulations must be followed and complied with.

### **2.4.2 Inspection and maintenance obligation**

The operator is under an obligation to only use the Floor saws when it is in a perfect and undamaged condition. The maintenance intervals shown in the Safety Manual must be strictly observed. Malfunctions and mechanical damage must be rectified without delay.

### **2.4.3 Spare parts**

Only original spare parts should be used. Otherwise damage may be caused to the Floor saws or damage to other property and personal injury may result.

### **2.4.4 Modifications**

No technical alterations should be made independently to the equipment and installation components in the form of additions or conversions without the written consent of TYROLIT Hydrostress AG. This concerns all additions and conversions that are not provided for by the system design.

### **2.4.5 Safety instructions in the individual chapters**

The chapters of this Safety Manual and of the Operating Instructions contain additional safety instructions. These make reference to specific potential dangers (residual dangers). The instructions must be followed closely and require that the actions or sequences of actions described are taken.

### 2.4.6 Correct application

Floor saws are designed and built for the following applications:

Cutting of asphalt and concrete (including reinforced concrete).

Cutting of parting cuts, flush cuts and joints in floors.

Only tools with the original hole pattern must be used.

If Floor saws are operated in a closed or underfloor area, the exhaust gases from combustion motors must be discharged into the open air.

The applicable mandatory limitations on use and parameters are contained in the Operating Instructions.

### 2.4.7 Abuse or misuse

- Use other than for the intended purpose constitutes abuse or misuse.
- Since improper use or misuse can sometimes results in considerable danger, details are given here of what we believe constitutes improper use or misuse.

The following applications are prohibited:

- Cutting of metal, wood and plastics.
- Cutting of loose parts (including in concrete)
- Operation in water and in explosion-protected areas
- Cutting without system and tool cooling  
(except for use in dry cutting with a special diamond tool)
- Cutting without the safety devices provided
- Incorrect or absence of waste water disposal (saw sludge)
- Cutting without the safety devices provided

### **2.4.8 Making the workplace safe**

Make sure that all water, gas and electric lines are turned off in the area where you are cutting. Find out whether it is permissible for such lines to be cut through.

Make sure that it is safe and permissible to cut reinforcements in the area of your cut.

Before starting work enough space should be created to ensure working without danger.

The workplace must be adequately lit.

Danger areas must be visibly cordoned off so that no-one can enter the danger areas during sawing.

The front, underneath and rear of the sawing area must be protected so that persons or equipment cannot be harmed or injured by falling parts or sawing sludge. Lumps of concrete that have been loosened must be secured against falling.

Breathing in the water fog that is created is a health hazard. Ensure adequate ventilation in sealed-off areas.

The sludge resulting from cutting is very greasy. Suitable steps must be taken (removal or cordoning off) so that persons do not slip and injure themselves.

Make sure you know how to alert first aid rapidly in case of an accident.

## **2.5 Responsibility**

### **2.5.1 Authorised personnel**

Work on or with Floor saws should only be performed by authorised persons. Personnel are considered to be authorised if they meet the necessary training and know-how requirements and they have been assigned a precise functional role.

### **2.5.2 Delimitation of authority (functional roles)**

#### **2.5.2.1 Manufacturer**

TYROLIT or its local agents in the EU are deemed to be the manufacturer of equipment components supplied by TYROLIT Hydrostress AG. Within the context of an integrated quality and safety control system the manufacturer is entitled to request from the operator information on its Floor saws.

#### **2.5.2.2 Operator (owner)**

As the primary legal entity, the operator is responsible for the correct use of the product and for the training and use of the authorised personnel. He sets out the mandatory skills and level of training of the authorised personnel for his company.

### **2.5.3 User (operator)**

- Sets up the Floor saws for the material to be cut or the material thickness.
- Performs sawing tasks independently and monitors these.
- Locates malfunctions and initiates or performs troubleshooting.
- Carries out servicing and simple maintenance.
- Monitors the correct functioning of the safety devices.
- Makes the site safe.

### **2.5.4 Service engineers**

The service engineer is an employee of TYROLIT Hydrostress AG or a person authorised by TYROLIT Hydrostress AG.

- Makes adjustments to the system.
- Performs repairs, complex service work and maintenance work.

## **2.5.5 Qualification and training**

### **2.5.5.1 Operator (owner)**

- Trained building expert in a management position
- Has relevant experience in personnel management and danger assessment.
- Has read and understood the "Safety instructions" chapter.

### **2.5.5.2 Operator (user)**

- Has been trained by a TYROLIT specialist member of staff on the operation of Floor saws or has attended a specialist course at a local trade association in-country.
- Has received an introduction (basic training) to the operation of the Floor saws from the manufacturer.

### **2.5.5.3 Service engineers**

- Has specialist professional training (mechanical / electrotechnical).
- Has attended product training at TYROLIT.

## 3 Design and function

### 3.1 Functional description

#### 3.1.1 System description

The overall function of all Floor saws always remains the same. A motor drives the saw blade. This is swung in order to penetrate the material to be cut. With the travelling motion the desired cut is then made.

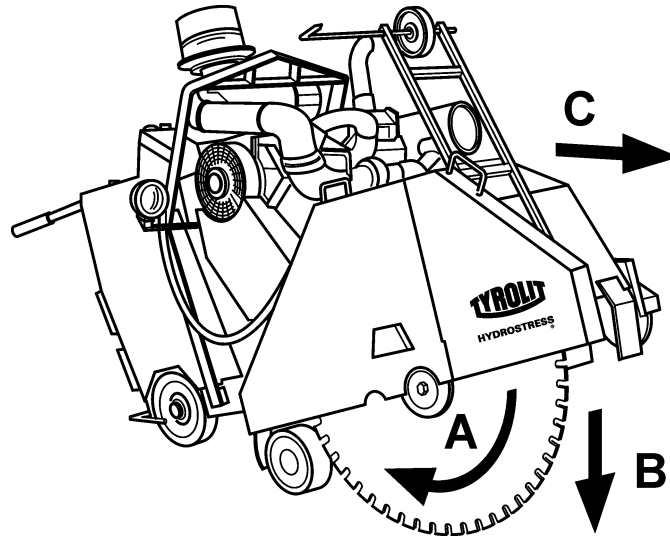

Fig. 3-1 System description

- A Blade drive
- B Insert saw blade
- C Cutting feed / travelling motion

Different joint cutter types are available in the various power classes.

### 3.1.2 Component description

#### 3.1.2.1 Drive motor

The drive motor drives the cutting tool. The power and the direction of rotation can be adapted according to the machine type. For the blade drive the following drives are used.

- Petrol motors
- Diesel motors
- Electric motor
- Hydrostatic motors

#### 3.1.2.2 Feed motor

Using the feed motor, the Floor saws can be moved forwards and backwards. For the travelling motion the following drive motors are used.

- Electric motor
- Hydraulic motors



#### Information

For low power and small sized Floor saws the feed motion can also be performed manually.

#### 3.1.2.3 Motor / cylinder for plunging motion

The swivelling motor / cylinder drives the swivelling part of the saw head. This allows the cutting tool to be inserted in the material to be cut. For the swivelling motion the following motors / cylinders are used.

- Electro-hydraulic motors
- Electro-hydraulic cylinders



#### Information

For low power and small sized joint cutters the swivelling motion can also be performed manually, e.g. by means of a hand wheel and spindle.



**3.1.2.4 Battery**

The supply of electricity to the starter motor is provided by a battery.

**3.1.2.5 Cutting tool**

The cut is performed with the help of the cutting tool. Depending on the material to be cut, both the type and diameter can be selected according to the machine specification.

**3.1.2.6 Blade guard**

The blade guard is a safety device and is positioned over the cutting tool. It prevents contact with the cutting tool when it is motion, intercepts flying parts and thus reduces the risk of injury. The blade guard acts as a spray guard at the same time.



## 4 Assembly, disassembly

### 4.1 General

#### 4.1.1 Safety instructions

Before proceeding read Chapter 2 "Safety instructions", 2-1 in this system manual. Be sure also to observe all the danger information given here and follow the instructions on how to prevent personal injury and damage to property.

#### 4.1.2 Personnel qualifications

Assembly and disassembly of Floor saws should only be carried out by authorised personnel. Personnel are only authorised where they meet the following requirements:

- has been trained by a TYROLIT specialist member of staff or has attended a specialist course at a local trade association in-country.
- the safety instructions in Chapter 2 must have been read and understood.

### 4.2 Saw blade assembly

During assembly note the direction of rotation of the saw blade and of the Floor saws. Check the saw blade for damage and wear (catch pins and hole). The saw blade specification and the blade diameter must be matched to the material to be cut. Use only original anchoring elements and note whether the anchoring screw has a right- or left-hand thread. Securely tighten the anchoring screw.

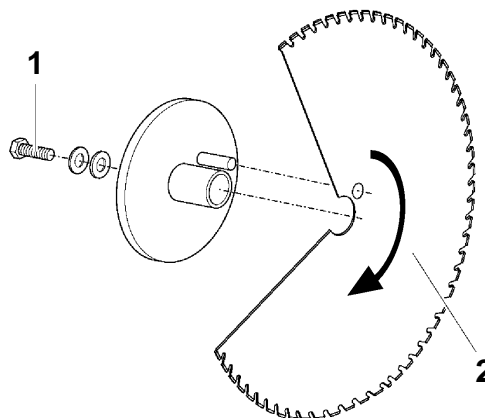

Fig. 4-1 Saw blade assembly

- 1 Original anchoring elements
- 2 Saw blade direction of rotation



## 5 Putting into service / Operation

### 5.1 Putting into operation

Each time that the Floor saws is put into service it must be checked to ensure that it is free of defects.

### 5.2 General

Before proceeding read Chapter 2 "Safety instructions", 2-1 in this Safety Manual. Be sure also to observe all the danger information given here and follow the instructions on how to prevent personal injury and damage to property.

#### 5.2.1 Safety instructions

It is essential to observe the following safety instructions, in particular in relation to the operation of the Floor saws.



### Danger

When performing the types of work described in this chapter, it is absolutely essential to wear the following personal protective equipment: helmet, goggles, protective gloves, safety shoes and hearing protection.

It is essential to ensure that the work instructions and procedures described in this safety manual are followed.

Failure to observe this regulation may lead to serious physical injury, or death, and to property damage.



### Danger

Electric shock due to defective electrotechnical equipment.

The electrotechnical equipment must be checked prior to each use and from time to time during prolonged use. Defective parts, such as e.g. cables and plugs, must be replaced immediately in the de-energized state by electrotechnically trained personnel.

Failure to comply with this regulation may lead to serious physical injury or death. Secondary damage such as fires may also occur.

**Danger**



**Danger from machine suddenly starting up.**

**Before switching on the system the operator must ensure that no other person is present in the danger areas.**

**Failure to adhere to this regulation may result in crushing or cut wounds to body parts and damage to property.**

**Danger**



**Hazard from falling building structures.**

**The building structure must be properly secured.**

**Failure to observe this regulation may lead to serious physical injury, possibly even death, and to property damage.**

**Danger**



**Noise danger.**



**When working with a Floor saws hearing protection must be worn.**

**If this instruction is not followed irreparable hearing damage may result.**

**Danger**



**Explosion hazard**

**Starting of fires and smoking in the immediate vicinity of Floor saws is strictly prohibited.**

**Failure to comply with this regulation may lead to serious physical injury or death. Secondary damage such as fires may also occur.**



### Warning



**Danger from segments or concrete chips flying off from the cutting tool.**

**Sawing without the blade guard is prohibited.**

**The danger area must be property secured.**

**Failure to observe this regulation may lead to serious physical injury or death.**

### Warning



**Danger from sharp cutting tool edges**

**Touching a cutting tool whilst it is still in motion is prohibited.**

**When touching cutting tools at a standstill it is recommended that protective gloves are worn.**

**Failure to adhere to this regulation may result in cut wounds to the hands.**

### Warning



**Hazard from toxic exhaust gases (carbon monoxide)**

**When a Floor saws is operated with a combustion motor in a sealed or underfloor area, it is essential that the exhaust gases are discharged into the open air.**

**Failure to adhere to this regulation may lead to symptoms of poisoning, or possibly death from suffocation.**

### Warning



**Danger of allergic reactions if skin comes into contact with hydraulic oil.**

**Persons who have an allergic reaction to hydraulic oil must wear protective gloves and goggles when carrying out work where they come into contact with hydraulic oil. Any areas of the skin affected must be rinsed immediately with copious amounts of water.**

**Failure to observe this regulation may result in allergic reactions or injury to the eyes.**

## 5.2.2 Personnel qualifications

Floor saws should not be operated by unauthorised persons. Personnel are only authorised where they meet the following requirements:

- Has been trained by a TYROLIT specialist member of staff on the operation of Floor saws or has attended a specialist course at a local trade association in-country.
- The user has read and understood the safety instructions in Chapter 2.
- The user is familiar with all the general rules of architecture.



## 5.3 Safety-related operator's controls

### 5.3.1 Blade guard

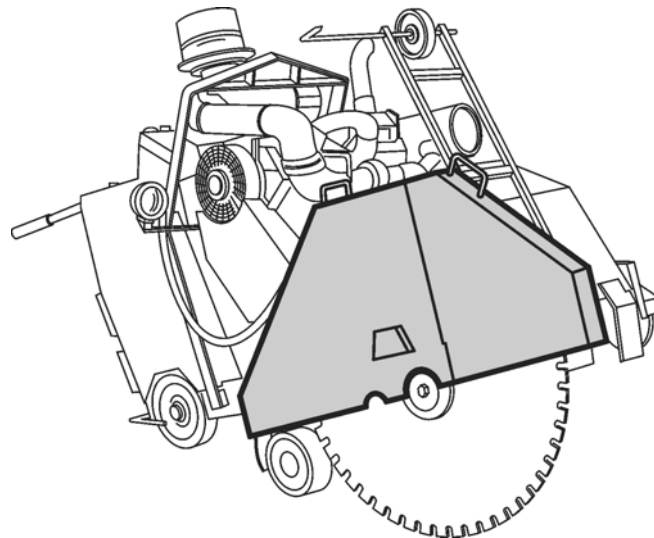

Fig. 5-1 Blade guard

The blade guard is a safety device. It provides protection from accidental contact with the cutting tool and from flying parts and at the same time acts as a spray guard. Working without the blade guard is prohibited.

### 5.3.2 Emergency Stop pushbutton

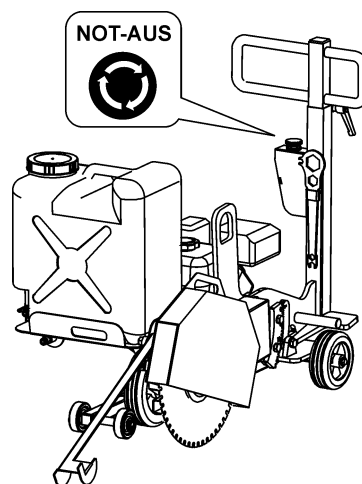

Fig. 5-2 Emergency Stop pushbutton

In danger situations the Emergency Stop pushbutton must be pressed immediately. Pressing the Emergency Stop pushbutton immediately halts the system and prevents the system being accidentally switched on again.

### 5.3.3 Controls and displays on the machines

The controls and displays of the individual machines and components are described in the corresponding Operating Instructions or instruction leaflets for each particular type of individual machine and component.

Example: Floor saws FSD930\*\*

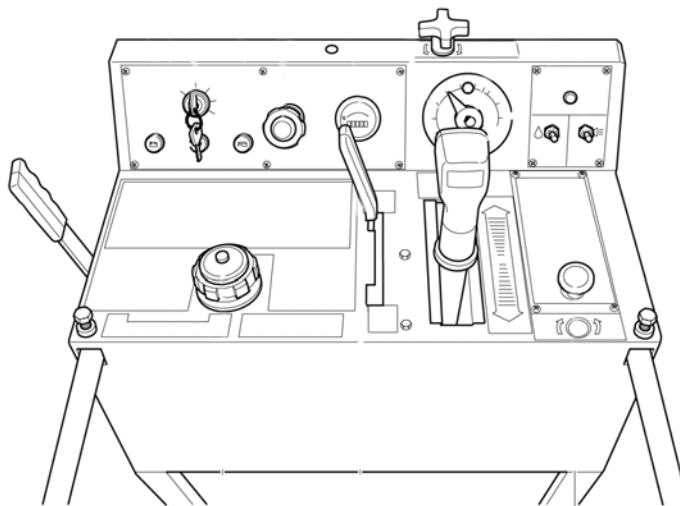

Fig. 5-3 Controls and displays

## 5.4 Operation

In order to guarantee that all work is carried out in complete safety, it is essential to perform the activities described in this Safety Manual.

### 5.4.1 Process checklist

#### 1. Approval from the supervision of works

Before any work commences the approval of the supervision of works must be obtained. The following points must be clarified:

- are there static concerns about the building structure?  
*Action:*  
*If structurally important bearing or support structures are cut through, this may have fatal consequences (static weakening or subsidence)*
- are electrical lines laid in the floor (ceiling)?  
*Action:*



### Danger

#### **Danger from electric shock**

**If one or more electricity lines is/are located in the floor (ceiling), it must be ensured that this/these has/have been de-energized and secured against re-energizing.**

**Failure to comply with this regulation may lead to serious physical injury or death. Secondary damage such as fires may also occur.**

- Are gas lines or sanitation lines laid in the floor?  
*Action:*  
*If gas lines or sanitation lines are present these must be emptied in advance.*
- Have loose parts been left in the floor (ceiling)?  
*Action:*  
*Loose or soft materials cannot be cut. They must therefore be removed first. Otherwise the result would be that the tool would jam or that individual segment would come away and be propelled.*
- how deeply are any longitudinally running reinforcements?  
*Action:*  
*If along the cuts to be performed there are reinforcements in the concrete, it is important to know how deep below the surface these may be located. If instead of the reinforcements being sawn through, the reinforcements are sawn along, the resultant heat could make the segments come loose with the result that the cutting tool is destroyed.*

## 2. Mark out cuts

The cutting line is used to accurately align the Floor saws. Floor saws are aligned with the cutting line by means of the cutting gauge. For floor cutouts the size and/or weight of the cut block must be taken into account.

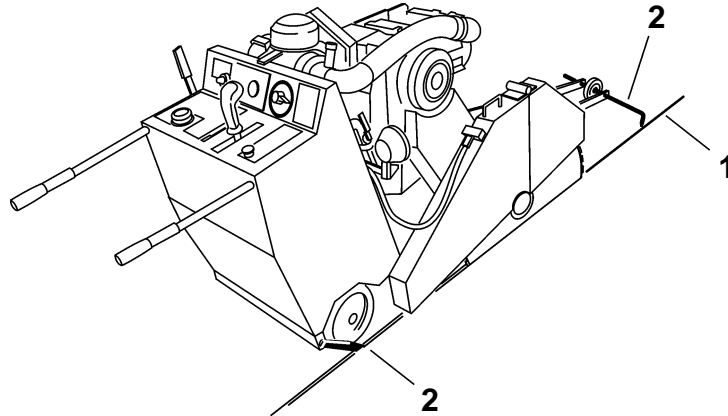

Fig. 5-4 Cutting line

- 1 Cutting line
- 2 Cutting gauge

## 3. Determine cutting sequence

Basically the cutting sequence must always be determined.

## 4. Secure danger area

The danger areas must be marked out and secured. During sawing operations no persons should remain in these danger areas.



### Warning

**Danger from segments or concrete chips flying off from the cutting tool.**

**The danger area must be property secured.**

**Failure to observe this regulation may lead to serious physical injury or death.**

**Danger areas**

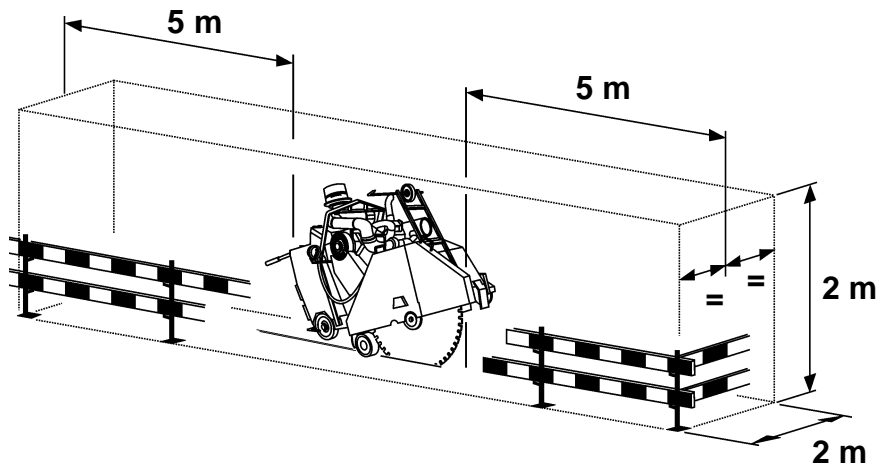

Fig. 5-5 Danger area

**Danger areas with floor cuts**

It is just as important to secure below the danger area. Individual concrete splinters or cutting tool segments may come loose and be projected. Securing below can consist of an H or U iron, but also wood, boards and so on.

(The securing must not be cut through).

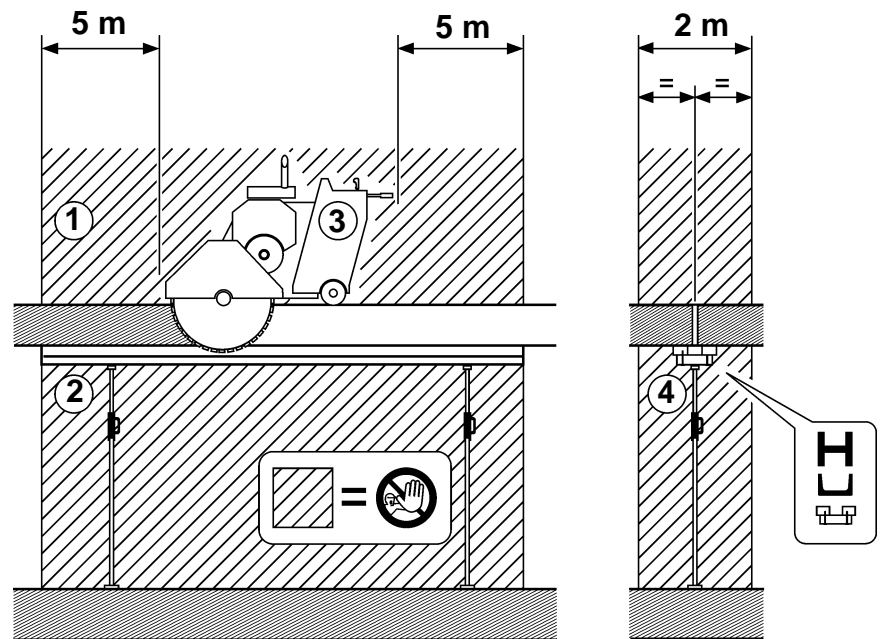

Fig. 5-6 Danger areas with floor cuts

- 1 Danger area
- 2 Danger area below
- 3 Floor saws with blade guard
- 4 Securing the sawing area below

**7. Mounting diamond saw blade**

During assembly note the direction of rotation of the saw blade and of the Floor saws. Check the saw blade for damage. The saw blade specification and the blade diameter must be matched to the material to be cut.

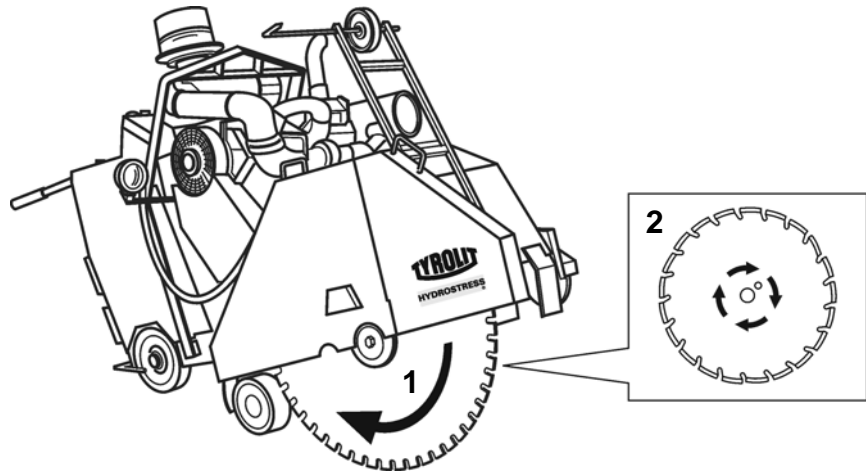

Fig. 5-7 1 Direction of rotation Floor saws  
2 Diamond saw blade direction of rotation

**8. Mount guard**

Work should only be performed with the blade guard mounted.



<b>Warning</b>
<p><b>Danger from segments or concrete chips flying off from the cutting tool.</b></p> <p><b>Sawing without the blade guard is prohibited.</b></p> <p><b>Failure to observe this regulation may lead to serious physical injury or death.</b></p>

**9. Check lubricants**

Before commencing cutting operations the lubricants must be checked and topped up as necessary.

**10. Connecting the water supply**

It must be ensured that the water supply is sufficient for the impending cutting work.

**11. Secure structural blocks**

Before sawing work begins, the blocks being cut must be secured against falling.



<b>Danger</b>
<p><b>Danger from falling building structures.</b></p> <p><b>The building structure must be properly secured.</b></p> <p><b>Failure to observe this regulation may lead to serious physical injury, possibly even death, and to property damage.</b></p>

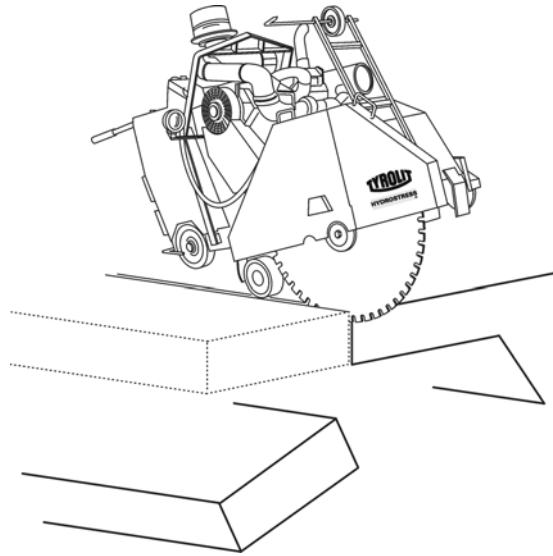

Fig. 5-8 Secure structural blocks

**Support cutouts**

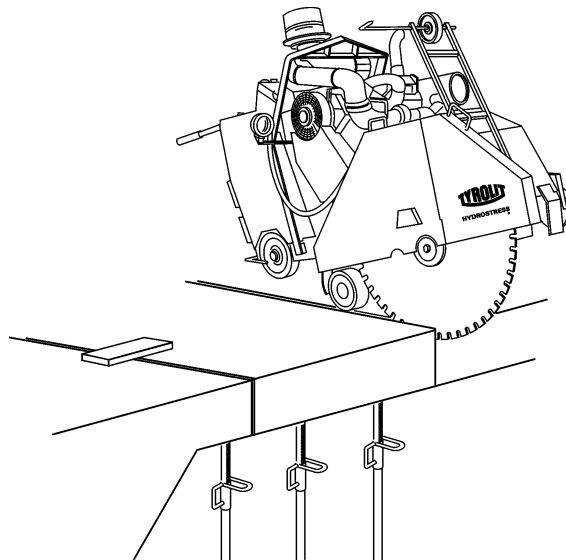

Fig. 5-9 Support cutouts



**Information**

For floor cutouts the cutout blocks must be supported with suitable building material or suspended and secured on a crane or other suitable lifting apparatus with sufficient load-bearing capacity.

**12. Carry out a test run**

Before the cutting work, it is recommended that a test run is performed on a short section in order to check the alignment of the Floor saws.

## 12. Pre-guide cut

### Definition

**Guide cut:** Cut for blade guide (7 - 10 cm)  
(Cut depth max. 10 % of the blade diameter)  
no reinforcement

Guide cuts serve to guide the diamond saw blade and should be followed for safety reasons.

**Precut:** The precut is performed with a small blade diameter and a large segment width.

Large depths cannot be cut in a single pass. Therefore, for blade diameters of 700 mm and above precuts must be made. The precuts must be performed with a diamond saw blade of small diameter and with wide segments.

The table shows how big the tool must be in relation to the cutting depth.

Saw blade diameter	Cutting depth	Precut required?
350 mm	90 mm	Guide cut with same blade required
500 mm	160 mm	
600 mm	230 mm	
700 mm	270 mm	Precut with smaller blade and wider segments required
800 mm	320 mm	
900 mm	350 mm	
1,000 mm	410 mm	
1,200 mm	480 mm	

## 13. Sawing, etc.

It is essential to observe the following instructions:

- The direction of travel and the plunging of the diamond tool must be checked
- The cutting gauge must be aligned on the cutting line
- Perform a short test run
- If the cutouts are performed with overcuts, please note table, 5-15. The length of the overcut is directly related to the cutting tool diameter selected, the plunging depth of the cutting tool and the thickness of the concrete.
- The cooling water must emerge at the cutting tool (check).
- Keep water feeds clean and check for damage.
- Do not cut on a loose substructure (rubble, sand) – this leads to heavy wear of the core of the tool.



- Remove exhaust gases

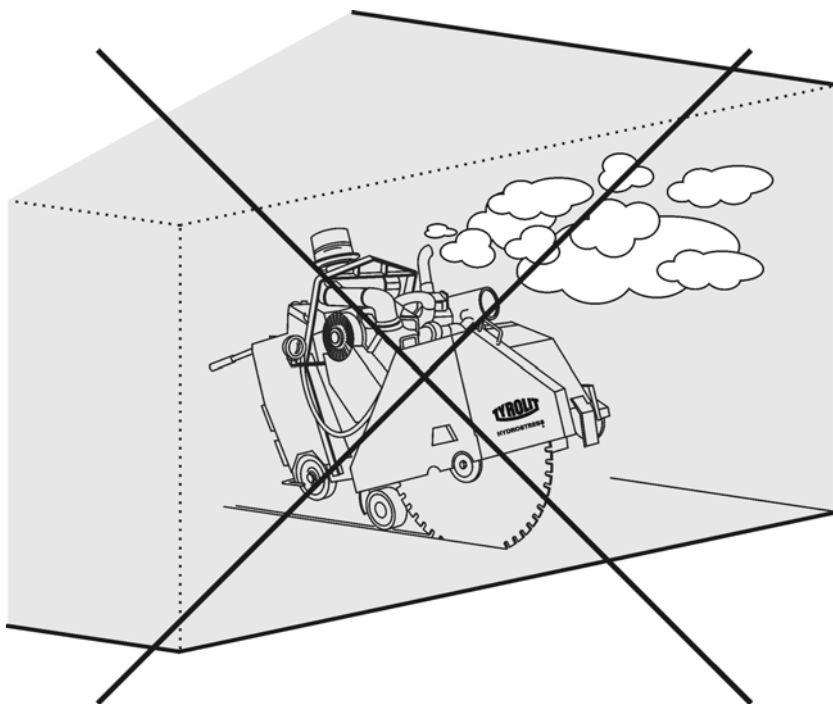

Fig. 5-10 Remove exhaust gases

## Warning



**Hazard from toxic exhaust gases (carbon monoxide)**

**When a Floor saws is operated with a combustion motor in a sealed or underfloor area, it is essential that the exhaust gases are discharged into the open air.**

**Failure to adhere to this regulation may lead to symptoms of poisoning, or possibly death from suffocation.**

- Sawing can now commence

### **Feed after the precut or guide cut**

Following the precut or guide cut more than 5 - 8 cm can be fed. The possible cutting depth is dependent upon the material to be cut, the size of the cutting tool, the blade specification and the drive power.

**Reinforcing irons in the longitudinal direction**

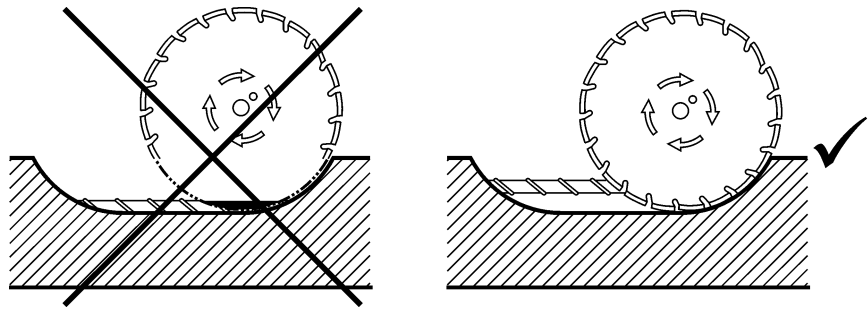

Fig. 5-11 Longitudinal reinforcements in the precut



**Information**

The depth of the precut must be selected to guarantee that any reinforcements running alongside the cut are completely cut through. Any guide cuts should be above the reinforcement

If the cutting tool runs along in the reinforcement, there is a danger of the cut drifting with heavy wear of the tool rendering it defective. The cutting of longitudinal reinforcements leads to strong vibrations and extreme wear of the tool.

**If the saw blade jams**

- Carefully withdraw from the cut with travelling or swivelling motions.
- If this is not possible: Disassemble cutting tool from Floor saws and remove cutting tool alone from the cut.

**At the end of each cut**

- Withdraw from the cut with the cutting tool running
- Move the diamond saw blade to the uppermost position

**Terminating the work**

To terminate sawing work correctly, proceed as follows:

- Switching off Floor saws
- Clean Floor saws (e.g. by spraying with water)

**14. Disposal of cutting sludge**

Once the sawing work has been completed the sawing sludge must be disposed of according to the normal environmental regulations in-country.

### 5.4.2 Overlap table

The following table shows by how much the cutting tool overcuts at both ends of the cut according to the penetration depth and the size of the cutting tool.

	Cutting tool <b>with maximum</b> penetration								Cutting tool <b>with minimum</b> penetration							
	Size of tool								Size of tool							
Concrete thickness in cm	Ø 500	Ø 600	Ø 750	Ø 800	Ø 900	Ø 1,000	Ø 1,200	Ø 1,500	Ø 500	Ø 600	Ø 750	Ø 800	Ø 900	Ø 1,000	Ø 1,200	Ø 1,500
5	2	2	2	2	1	1	1	1	15	15	18	18	20	21	21	27
10	6	5	4	4	3	3	3	2	20	22	25	26	28	29	32	37
15	14	10	7	7	5	5	4	3	23	25	29	31	32	35	39	45
20		18	12	11	9	8	7	5		28	33	34	37	39	44	51
25			19	17	13	12	10	7			35	36	43	43	49	56
30				26	20	17	13	10				38	43	45	52	60
35					30	24	18	13					44	47	54	64
40						36	24	17						48	55	67
45							31	22							57	69
50								44	27						58	71
55									34							73
60									43							73

Fig. 5-12 Table of overcut dimensions

## 5.5 Removal of the structural blocks

Removal of the structural blocks is dangerous and therefore particular care is called for. It must in particular be ensured that no persons remain in the danger areas and the securing and suspension or crane apparatus are adequately designed for the load to be held or lifted.

### 5.5.1 Removal with the help of a block and tackle

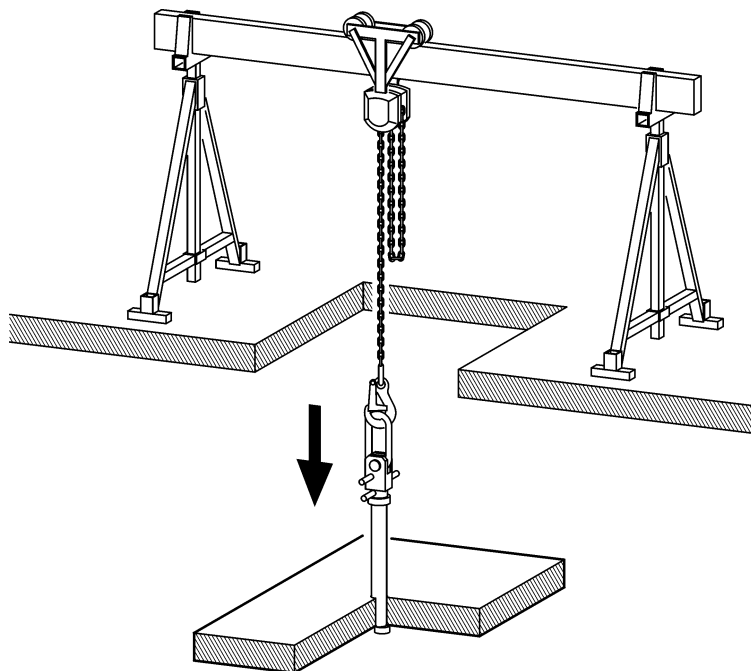
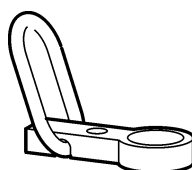

Fig. 5-13 Floor cutout cutting example

### 5.5.2 Using the correct load hook

2.5 t suspension device



4.0 t suspension device

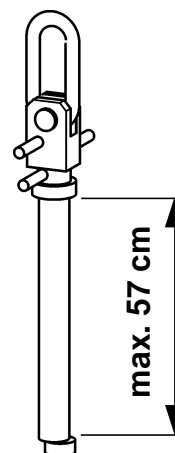

Suspension devices for various suspended loads

## 5.6 Securing of floor or ceiling cutouts

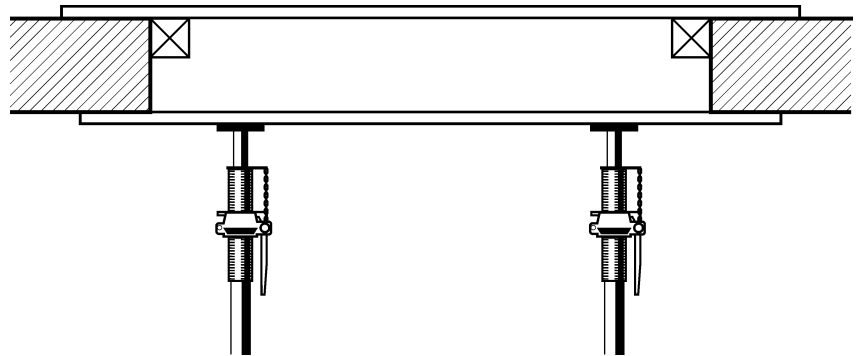

Fig. 5-14 Covering of floor or ceiling cutouts

### 5.6.1 Securing of large floor or ceiling cutouts

If a floor or ceiling cutout cannot be secured as shown in Fig. 5.6, 5-17, then it is essential that it is secured as follows.

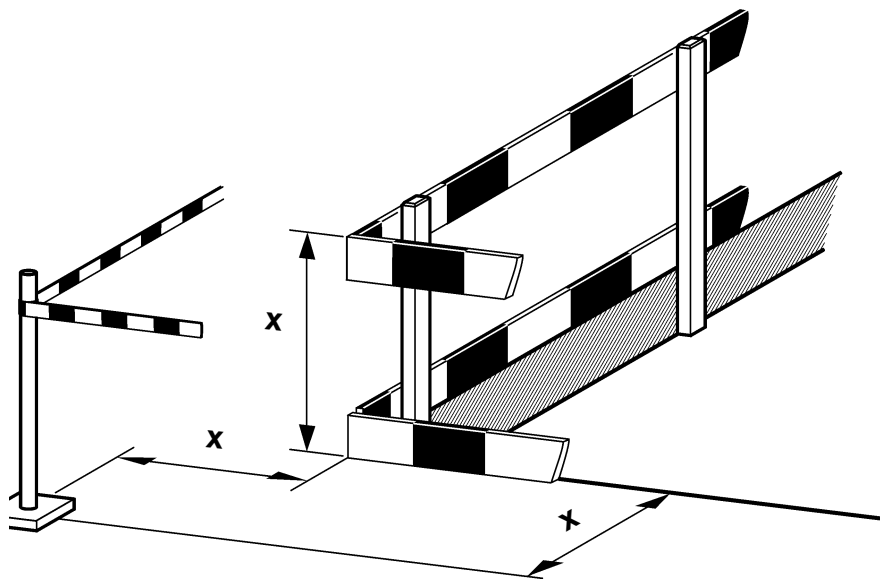

Fig. 5-15 Possibilities for barriers at hard edges

x Dimension in accordance with local regulations

## 5.7 Troubleshooting

Proceed systematically when looking for the causes of a fault.

The following table will help you to narrow down and rectify the source of the fault.

Fault	Possible cause	Solution
Saw blade does not rotate	Defective drive motor	Inform TYROLIT Hydrostress AG after-sales service
	Defective drive belts	Replace drive belt
	Drive belt not tensioned	Tension drive belt
	Saw blade jams	Lift blade from cut
No water at saw blade	Water valve shut off	Open water valve
	Water hose incorrectly connected	Couple water hose correctly
	Water pressure too low	Water pressure: min. 1 bar
	Water feed pipe interrupted, distorted, broken	Check the water supply
	Water pump defective	Replace water pump
	Pipes frozen, soiled	Thaw pipes, clean
Sawing power too low	Defective drive motor	Inform TYROLIT Hydrostress AG after-sales service
	Wrong saw blade	Inform TYROLIT Hydrostress AG after-sales service
	Cutting untrue (loose drive spindle)	Inform TYROLIT Hydrostress AG after-sales service
	Feed wheel over-running	Prevent over-running of feed wheels
	Cutting speed too high	In the case of hard aggregates or a lot of reinforcements, reduce the speed
	Saw blade polished	Sharpen saw blade with sharpening block
	Wrong fuel	Check fuel
	Defective bearing – strong vibrations, increased wear of tool	Replace bearing
Saw blade cannot be raised	Tool is jammed	Release tool and start up again
	Lifting motor / cylinder defective	Checking lifting motor / cylinder
	Hydraulic pump defective	Replace hydraulic pump
	Leaky hydraulic lines	Replace hydraulic lines
No power, though electric motor is running	Incorrect direction of rotation of electric motor, field of rotation monitoring relay is defective	Replace the rotary field monitoring relay

Fault	Possible cause	Solution
The electric motor buzzes after switch-on but delivers no power	Motor only runs with 2 instead of 3 phases	Check fuses on the power supply
The electric motor stops suddenly	Power supply interruption, protective motor switch has triggered because of: <ul style="list-style-type: none"> <li>• Overvoltage in the power supply</li> <li>• Voltage surge on power supply</li> <li>• Winding thermostat trips due to overheating of electric motor</li> </ul>	Check power supply <ul style="list-style-type: none"> <li>• Check power supply</li> <li>• Check power supply</li> <li>• Check motor cooling</li> <li>• Press reset key</li> </ul>
Electric motor does not run	Emergency Stop pushbutton has been pressed	Release Emergency Stop pushbutton
	Cable / plug connector loose or defective	Check cable / plug connector
	Defective contactor	Replace contactor
Overheating / overload	Electric motor overheated / overloaded	Restart motor and allow to run under no load. Wait for cooling

If you are unable to remedy a fault, please call our service centre (see Manufacturer's address II on the reverse of the title page).

To guarantee a rapid and professional solution to the problem, it is important that you have prepared as follows before calling:

- Try to describe the fault as accurately as possible
- Note the type and index of your Floor saws
- Have the Operating Instructions close to hand

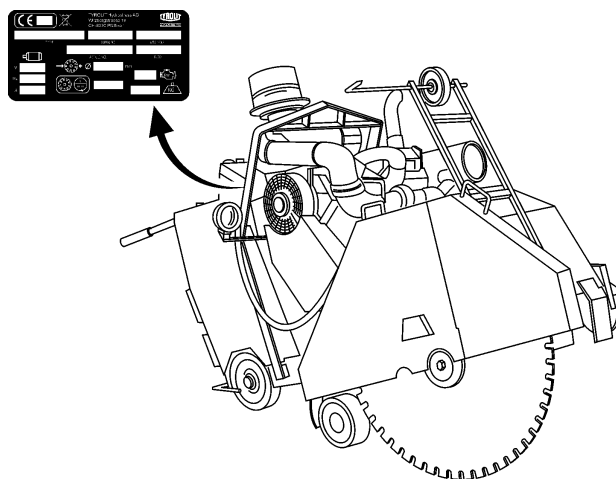

Fig. 5-16 Name plate





## 6 Maintenance

### 6.1 General

#### 6.1.1 Safety instructions

Before proceeding read Chapter 2 "Safety instructions", 2-1 in this Safety Manual. Be sure also to observe all the danger information given here and follow the instructions on how to prevent personal injury and damage to property.



### Warning

**Danger from sharp cutting tool edges**

**Touching a cutting tool whilst it is still in motion is prohibited.**

**When touching cutting tools at a standstill it is recommended that protective gloves are worn.**

**Failure to adhere to this regulation may result in cut wounds to the hands.**



### Warning

**Danger of allergic reactions if skin comes into contact with hydraulic oil.**

**Persons who have an allergic reaction to hydraulic oil must wear protective gloves and goggles when carrying out work where they come into contact with hydraulic oil. Any areas of the skin affected must be rinsed immediately with copious amounts of water.**

**Failure to observe this regulation may result in allergic reactions or injury to the eyes.**

#### 6.1.2 Personnel qualifications

Floor saws should not be operated by unauthorised persons. Personnel are only authorised where they meet the following requirements:

- have successfully completed, and hold a certificate from, user training at **TYROLIT Hydrostress AG** or corresponding technical courses at regional professional associations and federations.
- the safety instructions in Chapter 2 must have been read and understood.
- are familiar with all the general rules of architecture.

## 6.2 Maintenance interval table

The following maintenance work must be performed according to the specified cycles. Wear parts that are not subject to particular maintenance intervals should also be checked regularly for wear and adjusted or exchanged as necessary. For combustion motors the maintenance activities must be performed according to the separate maintenance instructions of the motor manufacturer.

		before each start-up	upon completion of work	weekly	annually	in the event of malfunction	in the event of damage
Floor saws in its entirety	Visual check	X				X	X
	Clean		X				
Hydraulic components	Hydraulic hose inspection (tightness / cleanliness)	X	X			X	X
	Coupling inspection (tightness / cleanliness)	X	X			X	X
Electrical components	Visual check	X				X	X
	Clean		X				
Water economy	Water line (tightness/ cleanliness)	X	X			X	X
	Blow out water (frost hazard)		X				
Water nozzles and feed hoses / cable For control unit see Operating Instructions	Clean		X				
	Inspection	X					
Saw blade	Inspection	X				X	
	Change						X
Accessible nuts and bolts	Retighten			X			
Flanges and blade holder	Clean		X				
	Change						X
toothed belt	Inspection	X		X		X	X
	Change				X		X

		before each start-up	upon completion of work	weekly	annually	in the event of malfunction	in the event of damage
Major service	Performed by TYROLIT Hydrostress after-sales service				X		

### 6.3 Inspection

Inspection activities are understood to be the work involved in checking wear parts, in order to exchange these where they show unacceptable levels of wear before they are able to cause a defect and a costly system failure.

Inspection activities are described in the Operating Instructions of the individual machines.

### 6.4 Maintenance

Maintenance activities are understood to be the maintenance work that must be performed in order to be able to guarantee trouble-free operation of the Floor saws. These activities usually consist of: cleaning, oiling, greasing, tool sharpening, etc.

Maintenance activities are described in the Operating Instructions of the individual Floor saws.

### 6.5 Corrective maintenance

Servicing activities are understood to be independently performed repair work. These may be a result of inspection if unacceptable levels of wear are detected in wear parts, or if defects arise.

Servicing activities are described in the Operating Instructions of the individual machines.



## 7 Disposal

### 7.1 General

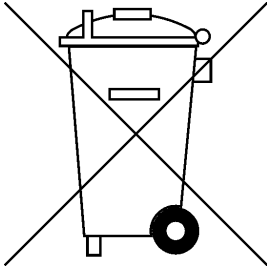

The operator can recycle or dispose of the Floor saws himself provided he observes the statutory provisions. In order to dismantle the Floor saws correctly and to properly remove the materials some knowledge in the area of mechanics and knowledge about differentiation of waste materials is necessary.

If during correct disposal doubts arise that represent a hazard for persons or the environment,

- the after-sales service of **TYROLIT Hydrostress AG** will be happy to provide information

### 7.2 Safety instructions

Before proceeding read Chapter 2 "Safety instructions", 2-1 in this Safety Manual. Be sure also to observe all the danger information given here and follow the instructions on how to prevent personal injury and damage to property.



#### Danger

##### Voltage warning

**Before working in an area identified in this way, the Floor saws must be fully disconnected from the power (voltage) and secured against being accidentally powered up again.**

**Failure to heed this warning may lead to death or serious injury.**

### 7.3 Personnel qualifications

Only personnel with basic technical training and who are in a position to identify the various material groups should be involved in disposal.

### 7.4 Disposal regulations

The normal national and regional rules and guidelines must be observed when disposing of the machines making up the Floor saws.

## 7.5 Disposal of installation components

### 7.5.1 Disposal regulations

The normal national and regional rules and guidelines must be observed during disposal.

### 7.5.2 Disposing of installation components

To allow proper disposal the components must be dismantled. This is performed by the client's personnel.



### Warning

Danger of injury from electric shock

Capacitors can still discharge in part of an installation even once all voltage supplies have been disconnected.

The dismantled parts of the installation are sorted by material and sent separately to the appropriate collection points. Ensure, above all, that the following parts are correctly disposed of.

#### The Floor saws consists of the following materials:

Cast aluminium	Rolled aluminium products
Bronze	Steel
Rubber	Rubber / Nylon fabric
Synthetic grease	Plexiglas

## 7.6 Obligation of notification

When a Floor saws is taken out of service and disposed of the manufacturer **TYROLIT Hydrostress AG** or the corresponding service centre must be informed of this.